

GUJARAT TECHNOLOGICAL UNIVERSITY**BE - SEMESTER-IV(NEW) EXAMINATION – WINTER 2022****Subject Code:3141907****Date:15-12-2022****Subject Name:Fundamentals of Machine Design****Time:10:30 AM TO 01:00 PM****Total Marks:70****Instructions:**

1. Attempt all questions.
2. Make suitable assumptions wherever necessary.
3. Figures to the right indicate full marks.
4. Simple and non-programmable scientific calculators are allowed.

		MARKS
Q.1	(a) Define factor of safety and state the important factors affecting the factor of safety.	03
	(b) Explain the following terms with neat sketches: (1) Tensile stress (2) Compressive stress (3) Principle Stress (4) Bearing pressure	04
	(c) Why square thread are preferable to V thread for power transmission? Also list out the advantage and limitation of threaded joints.	07
Q.2	(a) Discuss the importance of selection of materials in machine design.	03
	(b) Determine the moment of intertie of plane section, shown in figure-1	04
	(c) Name the different theories of failures of mechanical components made of ductile material. Explain the maximum shear stress theory giving conservative zone.	07
OR		
(c)	I –section beam made of alloy steel (Figure-2) for which allowable bending and shear stresses are 200 N/mm^2 . And 115 N/mm^2 respective. If the modulus of elasticity for beam is $210 \times 10^2 \text{ N/mm}^2$, determine: (1) The maximum bending moments of beam (2) The maximum shear force (3) The maximum radius of curvature of the beam as it bends under maximum bending moment.	07
Q.3	(a) Compare hollow shaft and solid shaft	03
	(b) Explain the following terms 1) Elasticity & Plasticity 2) Lateral strains & longitudinal strains	04
	(c) Determine the diameter of a solid shaft used for transmitting 30 kW power at 230 r.p.m. determine the diameter of hollow shaft, if the solid shaft is to be replaced by the hollow shaft. Take the ratio of inside to outside diameter is 6:8 and allowable shear stress of shaft as 50 MPa.	07
OR		
Q.3	(a) Explain basic type of lever with neat sketches.	03
	(b) Derive the design equation for shaft subjected to twisting moment only.	04
	(c) Design a knuckle joint to connect mild steel bars under a tensile load of 25 kN. The allowable stress are 65 MPa in tension, 50 MPa in shear and 83 MPa in crushing.	07
Q.4	(a) Distinguish between knuckle joint and cotter joint.	03
	(b) Define following with reference to beam with neat sketch:	04

- (i) Deflection, (ii) Slope and (iii) Flexural rigidity.
- (c) Derive strength equations of sunk key based on shear and crushing (or compression) failures. Show that square key is equally strong in shearing and crushing compare to rectangular key. **07**

OR

- Q.4** (a) Draw neat sketch of cotter joint showing all the parts. **03**
 (b) Prove that efficiency of self-locking square thread is less than 50% **04**
 (c) Distinguish between beams, columns and strut giving suitable examples with figure. **07**

- Q.5** (a) Explain with figure **03**
 a. Fluctuating stresses
 b. Repeated stresses
 c. Reversed stresses
 (b) Explain the phenomenon of self-locking and overhauling of power screws. **04**
 (c) What is endurance strength? Discuss the factors affecting endurance strength of material. **07**

OR

- Q.5** (a) Why nut is manufactured from phosphor bronze in case of power screws? And Define lead and state the relation between lead and pitch in case of threaded screws **03**
 (b) Explain any four Terminology of power screw with figure **04**
 (c) Derive Soderberg's equation and state its application to different types of loadings. **07**

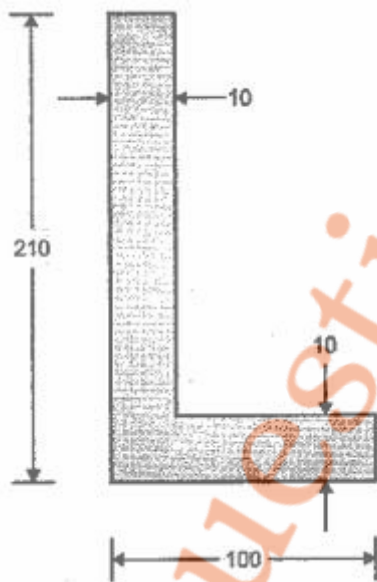

Figure :1 (Que: 2-B)

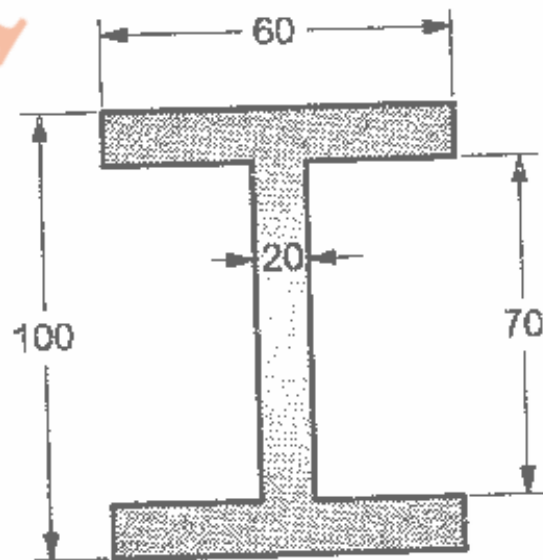

Figure: 2 (Que: 2-C)
